

## Synthetic Turf Athletic Field Drainage Design Assistance

AWD has been a leading manufacturer of geocomposite drainage products in North America for over 35 years. SITEDRAIN Strip 9400-T Series geocomposite strip drain products are engineered specifically for use in synthetic turf athletic field base drainage applications. SITEDRAIN Strip 9400-T Series is installed in a “flat-lay” orientation on top of the compacted subbase prior to installation of the permeable base layer and synthetic turf surface.

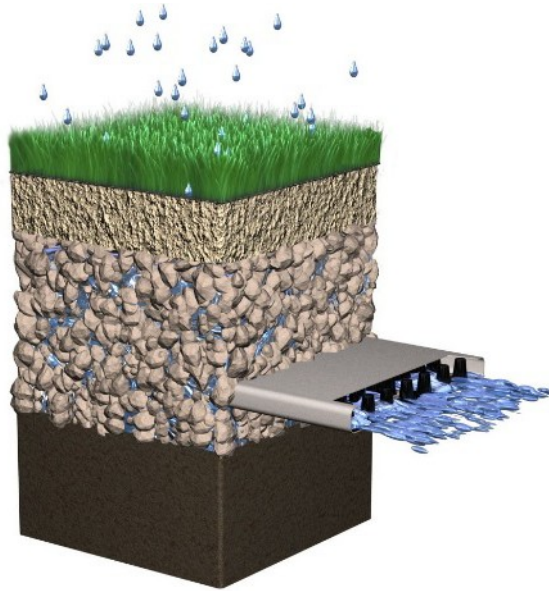

This Technical Bulletin is provided as a general resource and presents common considerations and example calculations used in the design of synthetic turf athletic field base drainage systems. This Technical Bulletin does not purport to address all design considerations or project-specific conditions.

The primary steps involved in designing a successful synthetic turf athletic field base drainage system are as follows:

- Estimate maximum water discharge
- Design drainage layout
- Determine spacing of SITEDRAIN Strip 9400-T Series
- Design transport system

## ESTIMATE MAXIMUM WATER DISCHARGE

The Rational Method can be used to estimate the maximum water discharge from an area less than 200 acres (8.7 million square feet) in size based on a design rainfall intensity:

Rational Method Formula:  $Q = ciA$

where:

- $Q$  = design discharge (gpm)
- $c$  = runoff coefficient (unitless)
  - Represents the fraction of rainfall converted to runoff/discharge
  - 1.0 is commonly used in athletic field drainage system design, which represents 100% of rainfall becoming discharge
- $i$  = design rainfall intensity (in/hr)
  - commonly based on historic rainfall data for the project location
  - Example: "10-Year Rainstorm Event"
- $A$  = catchment area, square feet (sf)
  - commonly the area of the synthetic turf field
  - May also include surrounding areas that drain to the field area

**Example 1:** Estimate the maximum water discharge from a synthetic turf athletic field with a catchment area of 390 ft x 190 ft using a design rainfall intensity of 1 in/hr.

**Solution 1:**

$$Q_{max} = ciA = 1.0 * 1 \frac{in}{hr} * (390 ft * 190 ft)$$

$$Q_{max} = 1.0 * 1 \frac{in}{hr} * 74,100 ft^2 * \left[ \frac{7.48 gal}{1 ft^3} \right] * \left[ \frac{1 hr}{60 min} \right] * \left[ \frac{1 ft}{12 in} \right] = 769.8 gpm$$

$$Q_{max} \approx 770 gpm$$

# DESIGN DRAINAGE LAYOUT

The design layout of SITEDRAIN Strip 9400-T Series will be dependent upon the slope of the subbase and the location and number of collector trenches. A typical athletic field design will have a compacted subbase crowned down the centerline of the field with a 0.5% slope to collector trenches on each sideline. In this type of design SITEDRAIN Strip 9400-T Series is most commonly installed in a chevron pattern, with strip drains running from the crown of the field to each sideline at 45-degree angles to the slope. Installing SITEDRAIN Strip 9400-T Series in this manner minimizes the distance water must travel laterally through the aggregate subbase before being collected and transported by the strip drain.

The following are example drainage layout details for reference:

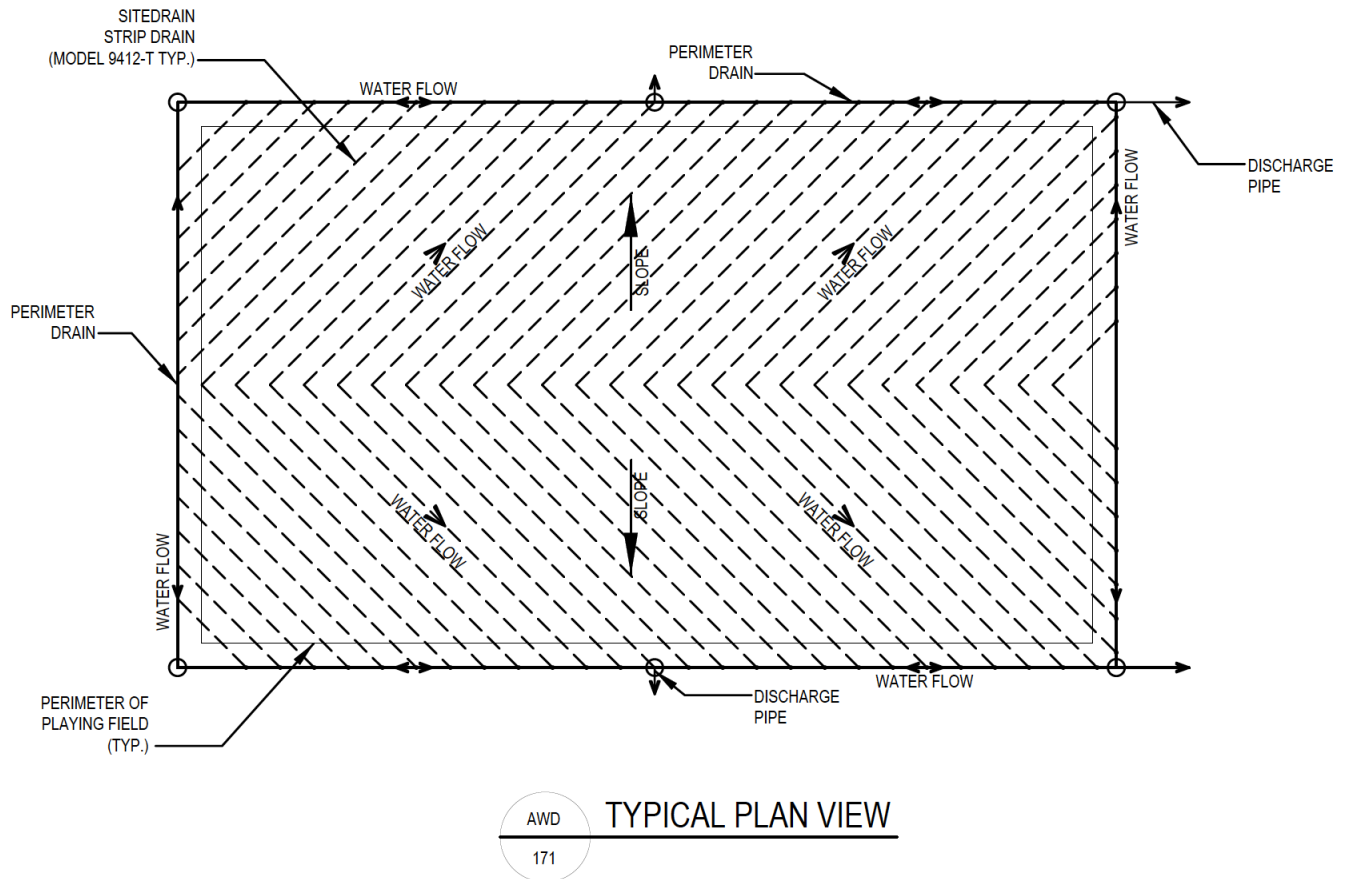

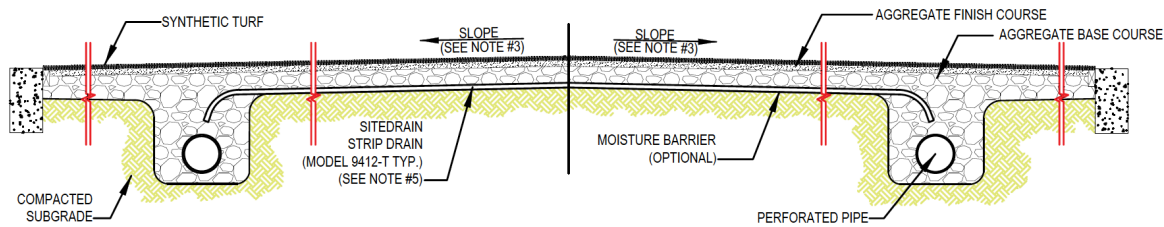

AWD TYPICAL CROSS SECTION  
172

## DETERMINE SPACING OF SITEDRAIN STRIP 9400-T SERIES

Synthetic turf athletic fields typically have high permeability turf and base layers which allow rainfall to rapidly infiltrate vertically through the synthetic turf and laterally through the aggregate base. It is common (and conservative) to design SITEDRAIN Strip 9400-T Series to accommodate for collection and transportation of the total maximum water discharge.

**Example 2:** Determine the maximum strip drain spacing required to accommodate the design flow rate of the synthetic turf athletic field presented in **Example 1** assuming the compacted subbase is crowned down the centerline of the field with a 0.5% slope to collector trenches on each sideline, and SITEDRAIN Strip 9412-T (12"-wide strip drain) is being used.

### Solution 2:

SITEDRAIN Strip 9400-T Series has been independent lab tested and verified to have an in-plane flow rate of 21 gpm when tested in accordance with ASTM D4716 at a hydraulic gradient of 0.1 and a normal stress of 3600psf. These are the common testing conditions used for determining strip drain flow capacity in synthetic turf athletic field design.

The crown down the centerline of the compacted subbase divides the field into two equal drainage areas, each with a maximum discharge rate of 385 gpm (770 gpm / 2).

Calculate the minimum number of SITEDRAIN Strip 9412-T strip drain runs required per side of field:

$$\# \text{ of Runs per Side}_{min} = \frac{Q_{max}}{Q_{strip}} = \frac{385 \text{ gpm}}{21 \text{ gpm}} = 18.33 \approx 19$$

Calculate the maximum spacing between SITEDRAIN Strip 9412-T strip drain runs:

$$\text{Strip Spacing}_{max} = \frac{\text{Length of Field}}{\# \text{ of Runs per Side}} = \frac{390 \text{ ft}}{19} = 20.5 \text{ ft}$$

**Strip Spacing<sub>max</sub> ≈ 20 ft**

SITEDRAIN Strip 9412-T spacing of 10 ft to 20 ft on center is common for synthetic turf athletic field designs depending upon project conditions and designer’s desired level of conservatism and field performance. Spacing strip drains closer will result in faster drawdown of water during rain events, will more rapidly accommodate flow from larger than design intensity rain events, and will provide better long-term performance. Spacing strip drains further apart may be acceptable in budget-conscious situations where rapid drawdown during design intensity rain events is not required. AWD does not recommend strip spacing of greater than 30 ft in any synthetic turf athletic field application regardless of design parameters as this requires water collected in the subbase to flow greater than desired distances before being intercepted and transported by a strip drain.

## DESIGN TRANSPORT SYSTEM

Water collected in the subbase by SITEDRAIN Strip 9400-T Series is typically transported to perforated pipe and aggregate trench drains located on the perimeter of the athletic field, where SITEDRAIN Strip 9400-T Series is terminated into these trenches as shown in the following details:

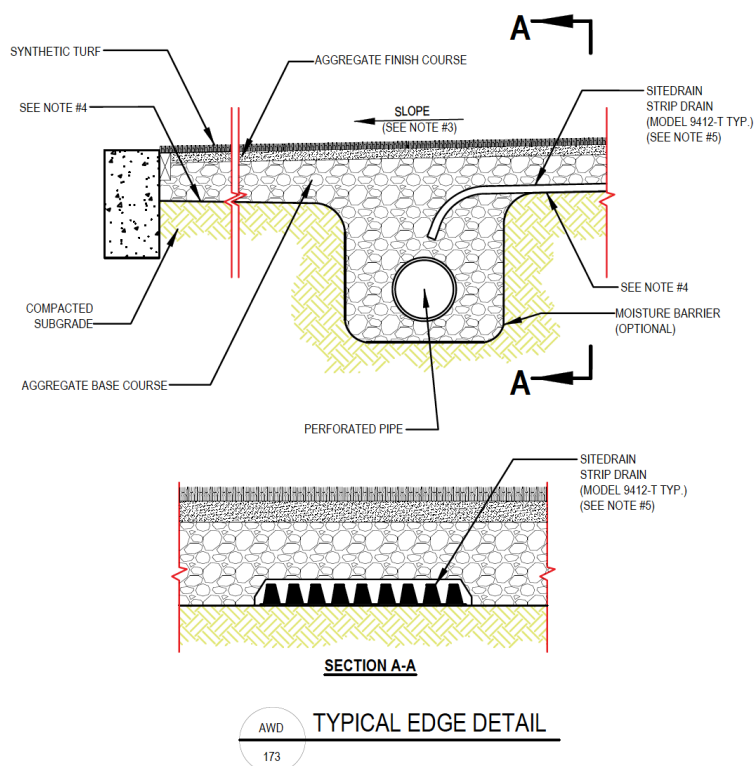

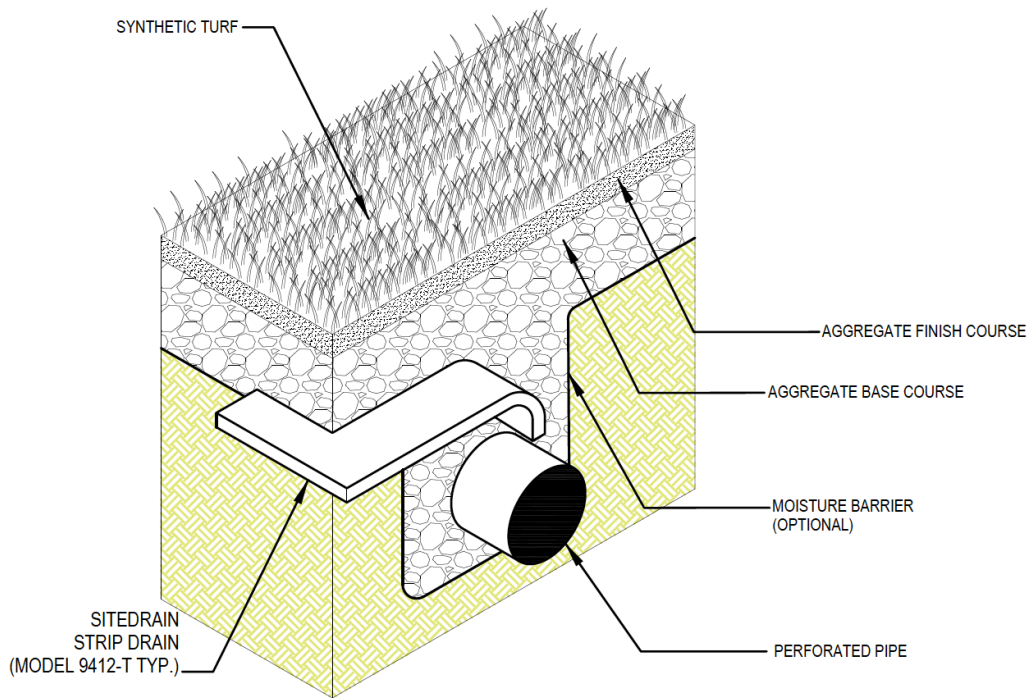

AWD TYPICAL EDGE DETAIL (ISOMETRIC)  
174

The trench drain transport system must be adequately sized to accommodate the design flow rate. In the examples above, each of the two sideline trench drains would need to accommodate 385 gpm. Each sideline trench drain must have at minimum one outlet. If the transport system is not adequately designed to collect, transport, and outlet the water received from the subbase drainage system, water may back up into the subbase and cause ponding on the field as it has nowhere to flow.

In some instances, the athletic field is intentionally designed to function as a water retention basin for large storm intensity events when there is not available or desirable maximum outflow capacity to another area. In these instances, the trench drain transport system outlets are intentionally designed to be the “bottleneck” in the overall field drainage system so that the water collected by the field will draw down at the desired rate so as not to overstress downstream drainage systems. Common trench drain sizes are approximately 2-ft wide by 4-ft deep, with sizing dependent upon the volume of water the designer would like the trench drains to be able to store before backing up into the subbase in rain intensity events that exceed the maximum outflow of the trench drain transport system.

Common perforated pipe sizes for synthetic turf athletic field applications range from 4-inch to 12-inch depending upon project specific design parameters. Manning's equation or pipe flow charts available from pipe manufacturers can be used to size the transport pipe and outlets accordingly.

**Please contact AWD Technical Support at (800) 242-9425 with any questions.**

**Disclaimer:** AWD assumes no liability for the accuracy or completeness of this information or for the ultimate use by the purchaser. AWD disclaims any and all express, implied, or statutory standards, warranties or guarantees, including without limitation any implied warranty as to merchantability or fitness for a particular purpose or arising from a course of dealing or usage of trade as to any equipment, materials, or information furnished herewith. This document should not be construed as engineering advice.